

ES2010-90219

DESIGN OF FARM WASTE-DRIVEN SUPPLY SIDE INFRASTRUCTURE FOR DATA CENTERS

Ratnesh Sharma, Tom Christian, Martin Arlitt, Cullen Bash, Chandrakant Patel

Hewlett-Packard Laboratories
1501 Page Mill Road, Palo Alto, CA

ABSTRACT

In this paper, we design a supply-side infrastructure for data centers that runs primarily on energy from digested farm waste. Although the information technology and livestock industries may seem completely disjoint, they have complementary characteristics that we exploit for mutual benefit. In particular, the farm waste fuels a combined heat and power system. The data center consumes the power, and its waste heat feeds back into the combined system. We propose a resource management system to manage the resource flows and effluents, and evaluate the direct and indirect economic benefits. As an example, we explain how a hypothetical farm of 10,000 dairy cows could fulfill the power requirements of a 1MW data center.

INTRODUCTION

Data centers, which provide controlled environments for Information Technology (IT) equipment, play an increasingly important role in modern society. However, due to their substantial power consumption and rapid growth in numbers, the design and operation of data center infrastructure is one of the primary challenges facing IT organizations and economies alike. Unprecedented growth in the demand for IT services has led to development of large, complex, resource-intensive IT infrastructures to support pervasive computing [1]. Emerging high-density computer systems and centralization of disaggregated IT resources are exhausting existing data center capacity [2].

Beyond the need for additional capacity, data centers also face uncertainty on the supply side. Reduced available capacity margins in the power grid, limited growth in the energy transmission and distribution infrastructure [3], emission control regulations [4] and the high cost of reliable energy present significant techno-commercial hurdles to availability of the robust IT infrastructure necessary to sustain economic growth.

A possible solution to these issues may exist courtesy of an unexpected partner. Data centers have a natural symbiosis with dairy farms and animal feeding operations. In particular, growth and concentration of the livestock industry in the United

States has created opportunities for the proper disposal of the large quantities of manure generated at dairy, beef, swine and poultry farms. Specifically, pollutants from unmanaged livestock wastes degrade the environment. The major pollution problems associated with these wastes are surface and ground water contamination and surface air pollution caused by odors, dust and ammonia. There is also a concern about the contribution of methane emissions to global climate change. Consequently, the livestock industry is required to properly manage their waste. Manure management systems that enable pollution prevention and produce energy are becoming increasingly attractive. Economic evaluations and case studies of operating systems indicate that the anaerobic digestion (AD) of livestock manures is a commercially viable bioconversion technology with considerable potential for providing profitable byproducts, including a cost-effective renewable fuel.

In this paper we explore a case study to design a farm-waste driven supply-side infrastructure for a 1MW IT data center which can support on the order of 1000 physical servers. We explain how the two complement one another, resulting in an economically and environmentally sustainable operation. The remainder of the paper is organized as follows: The next section provides relevant background information on IT data centers and the livestock industry. We then introduce the relevant supply-side technologies that we leverage. Next, we describe the supply-side design for a hypothetical 1MW IT data center. We also consider some design optimizations. Lastly, we conclude with a summary of our results.

NOMENCLATURE

HRT	Hydraulic Retention Time
AD	Anaerobic Digestion
UPS	Uninterrupted Power Supply
IT	Information Technology
CRAC	Computer Room Air conditioning units
LHV	Lower Heating Value
CHP	Combined Heat and Power
PCC	Point of Common Coupling
MMBTU	million BTU
MMSCF	million standard cubic feet

BACKGROUND

IT Data Centers

Data centers are controlled environments for housing IT equipment such as servers, storage and networking. Over time, the density of IT equipment in data centers has increased dramatically, primarily to achieve economic savings.

Figure 1 shows the basic data center building blocks. Electricity from the utility grid and/or onsite generation feed into the data center's switch gear. The switch gear, comprised of transformers and static switches with associated panels distributes power to both the cooling infrastructure and the IT infrastructure (via the Uninterruptible Power Supplies (UPS)). The cooling infrastructure is comprised of chillers, cooling towers, computer room air conditioning (CRAC) units and primary/secondary pumps. The IT infrastructure includes servers, network devices and storage devices housed in standard racks. The UPS maintains power quality during normal operation and provides energy storage to operate the IT infrastructure during brown outs or short power outages. The chillers provide chilled water to the data center room that houses the server racks and other IT equipment. Broadly, energy demands for a data center can be divided among electrical power for operation of IT devices and electrical power/energy to drive the cooling systems.

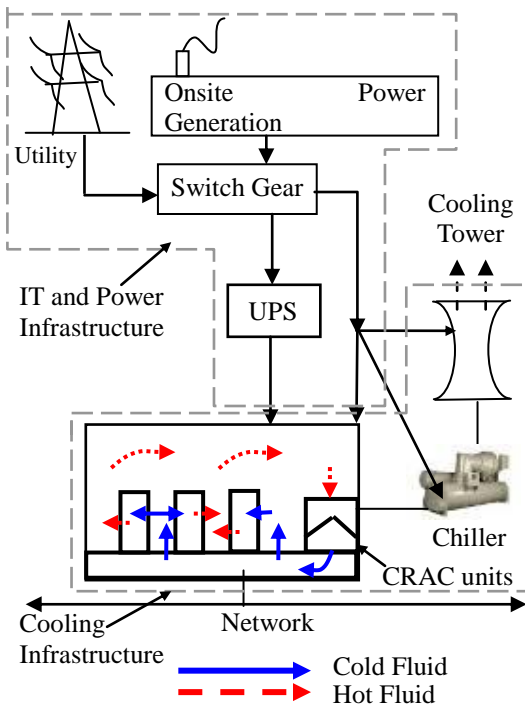

Figure 1: Data Center Building Blocks

The concentration of IT equipment within the data center poses several challenges. First, the power density can be quite significant, making it difficult to obtain sufficient electricity from the utility grid. Related to this, if the electricity from the utility is generated from non-renewable sources, the data center

may face economic penalties regarding (for example) its operational carbon footprint. For these reasons, onsite generation from renewable energy sources is attractive. Second, data centers generate a lot of waste heat. Current practices use substantial cooling infrastructures to remove this heat from the data center. However, this increases the data center's power usage significantly. This has motivated movement towards economization (e.g., outside air) and high temperature computing. This could lower both the capital and operational costs of cooling, and improve the quality of the waste heat by increasing its temperature.

Livestock Industry

The livestock industry is an important part of the global economy, primarily as a food source. Over time, economic factors have resulted in more concentrated operations. A consequence of this has been the aforementioned challenges resulting from the livestock waste.

The livestock industry has several important segments, two of which are dairy farms and beef feedlots. We consider these two segments briefly, as they have some important and relevant distinctions in terms of their energy potential [5].

The average dairy cow produces 54.7 kilograms of manure per day, approximately 20 metric tons/year [6]. Feedlot steers produce considerably less, in part due to dietary differences and because they do not spend a whole year in the feedlot. A feedlot with 50,000 steers will produce about 222,500 tons of manure each year, about 4.45 metric tons/year per steer [6].

There are two ways of producing power from manure: you can burn it and use the heat to produce steam which in turn can be used to spin turbines, or you can use an anaerobic digestion process to produce a biogas containing about 60-70% methane [7][8]. Combustion oxidizes nutrients in the manure and produces carbon dioxide and other emissions that could potentially be harmful to humans. Power from incineration is only economically viable in capacities around hundreds of MW. Anaerobic digestion retains the inorganics in the manure for reuse as fertilizer while the organics are broken down in a four stage process to yield methane and carbon dioxide. The methane can be used for heating, cooling or to produce power. Power can be generated using lean-burn reciprocating engines available at capacities up to a few MW. The effluent retains the nitrogen, phosphorus and potassium nutrients so it still has value as a fertilizer. As a final benefit, the effluent has few remaining decomposable compounds; since decomposition is what causes odor, anaerobic digestion also provides a solution to the odor problem.

The manure produced by one dairy cow in a day can generate 3.0 kWh of electrical energy [9][5]. For our hypothetical dairy with 10,000 cows, that is 30,000 kWh/day of electricity, enough power for an efficient 1MW data center. Essentially all of the energy consumed by the IT load in a data center is emitted as heat. This heat is typically transferred through one or more heat exchangers to an external cooling tower where it is rejected to the outside air. A data center co-

located with an anaerobic digester could utilize its waste heat for the anaerobic digestion process. Demand-side management of the IT load (i.e., to make more efficient use of the IT equipment), coupled with supply-side management of the resultant utility micro-grid, results in reduced operating costs and decreased greenhouse gas emissions. Further, as demand-side management reduces the power requirements for a given IT load, smaller herd sizes will be capable of supporting a significant IT load.

Dairy farms and feedlots are located in rural areas for a variety of reasons. IT data centers have typically been located in urban areas. However, the availability of high-speed wide area networks mitigates this issue for many IT operators, as the availability of power is more critical. Thus, in recent years companies such as Google, Microsoft and Yahoo! have all built large data centers in remote locations near power generation facilities. This practice has additional benefits, such as lower land prices and reduced transmission losses for electricity delivery. The use of farm waste for generation provides yet another opportunity for co-location.

SUPPLY-SIDE TECHNIQUES

In this section we describe the techniques we leverage and the motivations for our choices.

Anaerobic digestion

Anaerobic digestion (AD) is the process by which organic materials in an enclosed vessel are broken down by microorganisms, in the absence of oxygen [7][8]. Anaerobic digestion produces biogas (consisting primarily of methane and carbon dioxide). The ultimate yield of biogas depends on the composition and biodegradability of the organic feedstock, but its production rate will depend on the population of microorganisms, their growth conditions, and fermentation temperature [10].

Construction of anaerobic digestion systems for livestock manure stabilization and energy production has accelerated substantially in the past several years. The U.S. Environmental Protection Agency (EPA) estimates that there are currently about 125 operating digester projects at commercial livestock facilities in the United States. In 2008, farm digester systems produced an estimated 290 million kWh [11]. Besides generating electricity (244 million kWh), some operations use the gas as a boiler fuel, some upgrade the gas for injection into the natural gas pipeline, and some flare gas for odor control. Many of the projects that generate electricity also capture waste heat for various on farm thermal uses.

Currently, most digesters designed for energy production have natural gas engines which offer low acquisition cost, fast start-up, proven reliability, excellent load-following characteristics, and significant heat recovery potential. More importantly, these engines are not sensitive to fuel quality like fuel cells or microturbines. Electric efficiencies of natural gas engines, based on Lower Heating Value, range from 28% to over 40%. Waste heat recovered from the hot engine exhaust and from the engine cooling systems produces either hot water or low pressure steam for Combined Heat and Power (CHP)

applications. Overall, CHP system efficiencies (electricity and useful thermal energy) of 70 to 80% are routinely achieved with natural gas engine systems.

Potential distributed generation applications for reciprocating engines include standby, peak shaving, grid support and CHP applications in which hot water, low-pressure steam or waste heat-fired chillers are required. The economics of natural gas engines in on-site generation applications are enhanced by effective use of the thermal energy contained in the exhaust gas and cooling systems.

Operation of anaerobic digestion-driven power generation provides a unique opportunity for data center operators to improve the reliability and security of the energy supply while obtaining carbon emission credits by prevention of methane emissions. For digester operators, data centers provide a consistent year-round demand which removes the dependence on electrical price volatility from economics of digester operation while providing the additional environmental benefits, as mentioned before.

In this subsection, anaerobic digestion is used synonymously with biogas technology. Anaerobic digestion is a manure management tool that promotes the recovery and use of biogas as energy by adapting manure management practices to collect biogas. The biogas can be used as a fuel source to generate electricity for on-farm use or for sale to the electrical grid, or for heating or cooling needs. The biologically stabilized byproducts of anaerobic digestion can be used in a number of ways, depending on local needs and resources.

A typical biogas system consists of the following components:

- Manure collection
- Anaerobic digester
- Effluent storage
- Gas handling
- Gas use

Livestock facilities use manure management systems to collect and store manure because of sanitary, environmental, and farm operational considerations. Manure is collected and stored as liquids, slurries, semi-solids, or solids. The digester is the component of the manure management system that optimizes naturally occurring anaerobic bacteria to decompose and treat the manure while producing biogas. The choice of which digester to use is driven by the existing (or planned) manure handling system at the facility. Covered Lagoon, complete mix, plug flow and fixed film are the main types of digester technologies [12]. Another factor in the choice of digester is the hydraulic retention time (HRT) which is defined as the average number of days a volume of manure remains in the digester. Larger, centralized systems, with more material to handle and a need for a higher level of pathogen removal, will typically run at thermophilic temperatures (50-60°C) with a retention time of 3-5 days. Small and mid-sized systems can operate at mesophilic temperatures (35-40°C) with a retention time of 15-20 days. Temperature requirements for digestion can impose energy demands on the heating of digesters. The products of the anaerobic digestion of manure in digesters are

biogas and effluent. The effluent is a stabilized organic solution that has value as a fertilizer and other potential uses. A gas handling system removes biogas from the digester and transports it to the end-use location, such as an engine or flare. Gas handling includes: piping; a gas pump or blower; a gas meter; a pressure regulator; and condensate drain(s). Biogas produced in the digester is trapped under an airtight cover placed over the digester. Sometimes a gas scrubber is needed to clean or “scrub” the biogas of corrosive compounds contained in the biogas (e.g., hydrogen sulfide) before use. The recovered gas is 60-80 percent methane, with a heating value of approximately 600-800 BTU/ft³. Gas of this quality can be used to generate electricity; it may be used as fuel for a boiler, space heater, or refrigeration equipment; or it may be directly combusted as a cooking and lighting fuel.

Power Generation

Several options exist for generation of power from methane. Notable among those are microturbines, fuel cells and lean burn reciprocating engines. Microturbines provide high grade waste heat but have poor mechanical efficiency [13]. Fuel cells are the most efficient with least emissions but have constraints related to fuel quality, startup time and availability [14]. Waste heat from fuel cells is used for reforming of incoming fuel-cell gas to improve operational efficiency. Lean burn reciprocating engines provide a compromise between high mechanical efficiency, reliability and moderate waste heat generation [15]. Fuel cells have the highest installed cost, followed by microturbines and reciprocating engines. Table 1 shows a summary of electrical efficiency and installed cost of different power generation technologies. The choice of technology should be based on high electrical efficiency, high thermal output, low emissions, engine reliability and low maintenance costs.

	Electrical Efficiency	Installed Cost (\$/kW)	Maintenance Costs (cents/kWh)	Carbon Emissions (kg/ MWh)
Fuel Cells	50%	6,000	0.03	110
Micro Turbines	25%	2,500	0.01	215
Reciprocating Engines	40%	1,000	0.02	140

In reciprocating engines, thermal energy contained in the exhaust gas and cooling systems accounts for 60% of the inlet fuel energy. Heat in the engine jacket coolant accounts for up to 30% of the energy input and is capable of producing 90°C to 95°C hot water. Engine combustion exhaust gas temperatures around 400°C can be used to produce low pressure steam. Thus, approximately 70 to 80% of the energy of the fuel can be effectively utilized to produce both power and useful thermal energy.

Waste Heat Utilization

Waste heat from power generators can be used for cooling of data centers and/or heating purposes for buildings, green houses, digesters, etc. Waste heat (above 60°C) can be exploited by using conventional silica gel-water adsorption chillers to produce chilled water. Silica gel-water adsorption cycles can be driven by near-ambient temperature heat. Also, between 60 to 95°C, cooling capacity can be scaled based on water temperature variation. These chillers have a Coefficient of Performance (COP) of 0.7 [16] and can provide chilled water to cool the data center. The solid adsorbent bed desorbs refrigerant when heated and adsorbs refrigerant vapor when cooled, thus acting as a thermal compressor to drive the refrigerant around the system to provide cooling. The hot water regenerates the silica gel in the adsorbent chambers. The water vapor released from the silica gel by the hot water is condensed by cooling water from a cooling tower.

Another use of the waste heat is to maintain a suitable temperature in the digester [12]. Typically, steam may be charged into the manure feeding channels of the digester to maintain the charge at an appropriate temperature. As mentioned before, the rate and stability of biochemical reaction is temperature dependent. Waste heat from exhaust gases is a good candidate for such use.

Warm air from the data center can be mixed into the barn ventilation system to reduce heating load in the farm. Wherever possible, air distribution systems can offset a fraction of heat load with infiltration of data center exhaust air.

DESIGN

For the purpose of our analysis, we consider a 1MW data center. Air handling unit power demand is assumed to be 10% of the IT power demand at 100kW. To eliminate power demand for cooling, the cooling infrastructure comprises of waste heat driven adsorption cooling systems. The total electrical demand profile of the data center is considered constant for the purpose of this paper. Annual data center electrical energy consumption is estimated to be 9.6GWh.

The supply side infrastructure consists of a *digester, biogas handling, power generation and waste heat driven cooling* subsystems (see Figure 2). We consider a dairy farm with 10,000 cows with an average daily manure production of 547 metric tons. The anaerobic digester is operated year round and has an upright complete mix design. Waste heat from power generation systems is used to maintain digester temperature at 40°C. This is achieved by injection of steam generated from the hot exhaust of the power generation system. The hydraulic retention time is of the order of 10 days. The digester subsystem handles manure from the farm and maintains a solid concentration of around 10%. Some manure processing may be necessary to maintain consistency. Further reduction in HRT can be achieved by adding plastic media coated with anaerobic bacteria [12]. The depleted biomass or effluent retains inorganics and is stored for use as fertilizer.

The biogas handling system scrubs the gas to remove corrosive chemicals like hydrogen sulfide before storage.

Ferrous sulfide obtained from the process can be reduced in the presence of air to obtain elemental sulfur for other uses. Biogas produced in the digester is at a temperature of 40°C and should be cleaned to prevent corrosion and damage of power generation equipment. Methane accounts for 60-70% of the biogas produced, amounting for an annual production of 6.4 million cubic meters (240 MMSCF). The power generation system comprises of a low BTU gas fired lean-burn reciprocating engine driven generator set [17]. With an electrical efficiency of 37%, the generator provides power for the IT equipment and air handling units in the data center and refrigeration equipment on the farm. Based on design methane production, the system can generate over 10.8GWh annually. This implies that a total demand of 1.2MW can be supported without grid power. Apart from the data center demand, onsite generation can support electrical demand on the farm. Waste heat from engine exhaust will be used to generate low pressure steam for steam injection and hot water needs. Engine jacket cooling water will be used to produce 90°C hot water for the data center cooling system. It is assumed that only 70% of the available waste heat can be extracted due to heat transfer losses. The available waste heat from the power generation system is estimated at 17 GJ/hr (160 Therms/hr).

Waste heat driven adsorption cooling systems can cool data center equipment as well as satisfy the refrigeration demand of the dairy farm. The hot water demand for data center cooling is 4.5 MMBTU/hr while that for dairy cooling is 0.5 MMBTU/hr [12]. The total waste heat potential of the generation system is 16 MMBTU/hr (~17GJ/hr). Overall, the total hot water demand for cooling system is 40% of available waste heat potential. The balance waste heat, mostly in the form of low pressure steam, is used for maintaining optimum temperature (40°C) in the digester and for process heating in the farm. Assuming each cow produces 55kg (100lbs) of manure per day [6] and the digester charge needs to be heated by 30°C (above ambient), the steam requirement in the digester is estimated at 0.33kg/s (44lbs/min).

A detailed process flow diagram is shown in Figure 3. Clean biogas generated in the digester facility, marked “A”, is piped to the gas generator set. The generator provides power to the data center power distribution system through a system of UPS and power distribution units (see Figure 1). Waste heat from the engine cooling jacket is used to heat hot water in the primary heat recovery unit (B). Additionally, heat from the engine exhaust is recovered in the secondary heat recovery unit (C) to further heat the hot water beyond 100°C. The flash chamber (D) allows generation of steam and hot water for different site needs. Pressure in the flash chamber is controlled to alter the rate of steam generation. Steam is used for heating the digester and other heating needs in the farm (G). Hot water from the flash chamber is used in the desorber of the adsorption cooling system (E). It is mixed with make-up water to account for the loss due to steam discharge. Chilled water from the adsorption system is fed into the site cooling system which serves the data center and the farm. A primary-secondary loop

can be added if needed. Control valves can divert water to the data center (F) based on demand.

With change in farm and data center demand, biogas can be diverted to the boiler (H) to generate steam for hot water needs, thus reducing power generation. Such decisions can also be made based on maintenance schedules and operating cost. Multiple smaller units can be installed to manage generator downtime with additional power draw from the grid. Based on availability, natural gas or biogas will be used to fire boilers to provide steam and hot water for cooling and heating needs.

OPTIMIZATION

Given the multiple uses of methane, namely, to produce steam, generate power or just flare, standard optimization techniques can be used to determine the utilization levels for each source so that a sustainability metric, such as loss in available energy or carbon emissions, or the Total Cost of Operation (TCO) can be minimized [18]. Also, methane availability can change with time of day, seasons and unplanned events. For example, an optimization problem can be formulated for a supply-side infrastructure with the following constraints.

$$S_{i,\min} < S_i < S_{i,\max} \quad (1)$$

$$\sum S_i = D \quad (2)$$

where S_i is the output of the i th source; $S_{i,\min}$ and $S_{i,\max}$ are the minimum and maximum bounds, respectively, on the production of the i th source; and D is the total demand. The objective function to be minimized will be:

$$\min\left(\sum F_i(S_i)\right) \quad (3)$$

where F_i is the cost function corresponding to the i^{th} source.

The above methodology can be extended for different types of dependent or uncorrelated demand (like hot water, chilled water, steam, electricity). In certain cases, elasticity of demand and supply needs to be considered. In the case of CHP, a constraint related to heat required can be added, as well as, an additional term in the objective function indicating impact of heat utilization. Metrics like water usage energy (WUE) [19] can be included as a constraint to limit embedded energy in direct and indirect water usage.

ECONOMICS

The previous sections have demonstrated that a farm waste-driven supply-side infrastructure would be a viable source of power for IT data centers. An important topic yet to consider is the farmer’s perspective; what is in this for them? We believe that there are numerous reasons why dairy farmers and feedlot owners would benefit. We elaborate on these below.

Financial cost and associated risks are perhaps the most important consideration. Existing farms that have invested in supply-side infrastructure often do so only if a power-purchase agreement can be signed. Otherwise, the return could be too

speculative to justify the capital investment. A data center has substantial, continuous, and long-term power needs. Thus the data center owner could sign the power purchase agreement and provide the assured return desired by the farmer.

Similarly, in the near future regulations are expected on Greenhouse Gas (GHG) emissions. Since methane is 21 times more damaging than carbon dioxide, the farm waste system could provide the farmer carbon offsets for every ton of methane captured and used. This would translate into a cost savings when compared against a penalty (e.g., a carbon tax) if the methane is not captured and used effectively. As an important component of a cap and trade system for reducing GHG emissions, offsets provide companies with the flexibility to reduce GHG emissions while controlling costs in transition to a clean energy economy [20].

Large dairy farms and feedlots are already compelled to have waste management plans in place. While an overview of existing waste management plans is beyond the scope of this paper, the proposed system offers several advantages. First, it eliminates the odor that is typically associated with large farms. This issue often generates negative publicity for farmers and opposition to new farms. Second, a byproduct of the process is a rich fertilizer, so an existing use of manure is not lost.

Lastly, an existing “rule of thumb” is that farms north of the 40th parallel cannot use anaerobic digestion to generate power [8], as it is believed that all of the methane produced would have to be used to heat the manure to the optimal operating temperature. Instead, the methane is simply flared off, losing out on the potential energy benefits; flaring does, however, substitute CO₂ for methane as a less-objectionable GHG emission. Combining the farm-waste supply-side infrastructure with an IT data center would enable farmers to use waste heat for the digestion process, potentially making power generation economically feasible in colder climates than previously thought possible.

For all of these reasons, we believe that there is mutual benefit in combining farm-waste-driven supply-side infrastructure with IT data centers. At the very least, the “conventional wisdom” around farm waste management needs to be revisited.

CONCLUSIONS

Contemporary data centers are increasingly co-located with power generation and/or cooling resources to reduce operating costs. The existence of large dairy and animal feeding operations presents another co-location opportunity, one where the heat output from the data center can be used to develop synergy with its energy source. Anaerobic digestion of animal waste produces biogas containing 60-70% methane that can be used to generate power. The end result is a relatively odor-free effluent that retains value as fertilizer. Heat from the data center and the generation process can be used to increase the

efficiency of the anaerobic digestion process, for space heating or to provide direct cooling through an adsorption chiller.

This paper presents a hypothetical case study in which an anaerobic digester associated with a dairy having 10,000 cows is able to provide power for a 1MW data center, perhaps a 5,000 sq. ft. facility at a power density of 200 watts/sq. ft. Alternatives for methane production are discussed, as are alternatives for power generation that utilize the methane, and we explore possible uses for waste heat in the associated processes. Selecting from these technologies, we present a design for a workable system for co-generation and discuss system optimization; a detailed financial analysis of the technologies is beyond the scope of this paper, but is planned for future work. Finally, we look at the potential benefits and potential favorable economic impact for the farmer. We have shown that anaerobic digestion provides an effective mechanism for managing farm waste, controlling odors and reducing GHG emissions in addition to providing a fuel source for power generation. In return, the co-located data center provides a convenient market for the power generated by the anaerobic digestion system.

ACKNOWLEDGMENTS

The authors thank Randy Arlitt for providing information on the cattle raising process.

REFERENCES

1. “Report to Congress on Server and Data Center Energy Efficiency, Public Law 109-431”, U.S. Environmental Protection Agency, ENERGY STAR Program, Aug. 2007.
2. The Uptime Institute, “Heat density trends in Data Processing, Computer systems and Telecommunications Equipment”, White Paper issued by The Uptime Institute, 2000.
3. “2007 Long-Term Reliability Assessment (2007-2016) – The reliability of bulk power system”, North American Electric Reliability Corporation, Oct. 2007.
4. <http://www.arb.ca.gov/cc/factsheets/ab32factsheet.pdf>
5. “Comparison of Methane Production Potential Estimates for Livestock”, <http://www.epa.gov/agstar/>, Dec. 2008.
6. MacDonald et al., June 2009, “Manure Use for Fertilizer and for Energy Report to Congress”, US Department of Agriculture.
7. “Anaerobic Digesters”, Agricultural Utilization Research Institute, <http://www.auri.org/>
8. Lusk, P, “Methane Recovery from Animal Manures: The Current Opportunities Casebook”, National Renewable Energy Laboratory, NREL/SR-580-25145, Sep. 1998.
9. “Biomass Energy: Manure for Fuel”, State Energy Conservation Office, Texas http://www.seco.cpa.state.tx.us/re_biomass-manure.htm
10. MacDonald, J.M. and McBride, W.D., “The Transformation of U.S. Livestock Agriculture: Scale, Efficiency, and Risks”, U.S. Department of Agriculture, Economic Research Service. EIB-43. Jan. 2009.
11. “Anaerobic Digesters Continue Growth in U.S. Livestock Market”, <http://www.epa.gov/agstar/>, Feb. 2009.

12. Roos, K.F. and Moser, M.A., "A Manual For Developing Biogas Systems at Commercial Farms in the United States-AgSTAR Handbook", EPA, Second Ed.
13. "Technology Characterization: Micro-turbines", Climate Protection Partnership Division (EPA), Mar. 2002.
14. "Technology Characterization: Fuel Cells", Climate Protection Partnership Division (EPA), Apr. 2002.
15. "Technology Characterization: Reciprocating Engines", Climate Protection Partnership Division (EPA), Feb. 2002.
16. Saha, B.B., Akisawa, A., Kashiwagi, T., "Thermodynamic Analysis of Adsorption Refrigeration Cycles", Energy Conversion Engineering Conference, Jul. 1997.
17. "Low BTU gas generator sets", Cummins Power Generation,
<http://cumminspower.com/www/literature/brochures/F-1523-LowBTUGensets-en.pdf>,
18. Hernandez-Aramburo, C.A.; Green, T.C.; Mugniot, N., "Fuel consumption minimization of a microgrid," *Industry Applications, IEEE Transactions on* , vol.41, no.3, pp. 673-681, May-Jun. 2005.
19. Sharma, R.K., Shah, A., Bash, C.E., Christian, T., Patel, C.D., "Water Efficiency Management in Data centers: Metrics and Methodology", IEEE ISSST Conf., May 2009, Tempe, AZ.
20. "Carbon Offsets Overview", International Emissions Trading Association <http://www.ieta.org>.

FIGURES

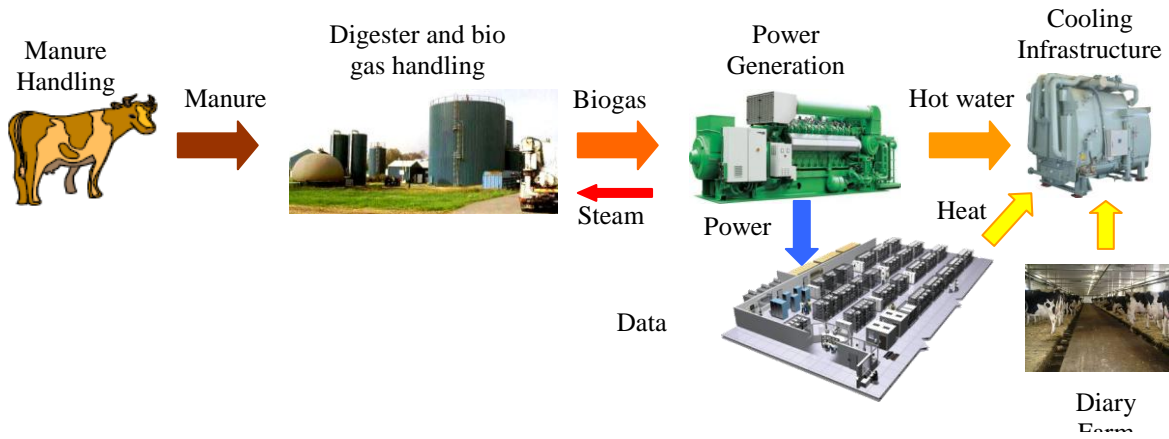

Figure 2: Flow chart of material and energy flow in the facility

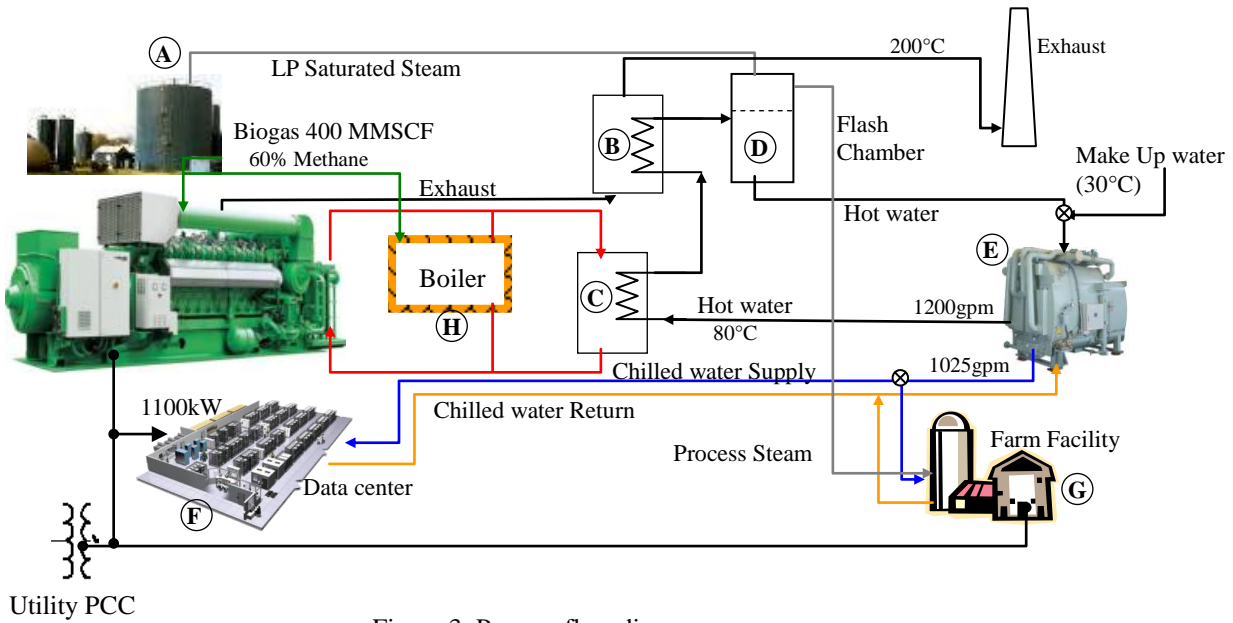

Figure 3: Process flow diagram