



Deploying a Model-Based Diagnosis System in the Manufacturing Test Environment

Chris Preist
Agency and Mediated Communications Department
HP Laboratories Bristol
HPL-97-22
January, 1997

automated
diagnosis,
model based,
manufacturing test

In this paper, we describe the deployment of a prototype model-based diagnostic system, JADE, in a manufacturing test process at Hewlett-Packard's Grenoble Personal Computer Division (GPCD), one of the divisions responsible for manufacturing Hewlett-Packard's PC products. Development of the prototype was carried out at Hewlett-Packard Laboratories, Bristol, and has subsequently been further developed to become the Hewlett-Packard Fault Detective product.

Deploying a Model-Based Diagnosis System in the Manufacturing Test Environment

Chris Preist

1. Motivation

In this paper, we describe the deployment of a prototype model-based diagnostic system, JADE, in a manufacturing test process at Hewlett-Packard's Grenoble Personal Computer Division (GPCD), one of the divisions responsible for manufacturing Hewlett-Packard's PC products. Development of the prototype was carried out at Hewlett-Packard Laboratories, Bristol, and has subsequently been further developed to become the Hewlett-Packard Fault Detective product.

2. The Manufacturing Test Process

Test is an essential part of manufacture, to ensure that poor quality goods are not shipped to customers. In the manufacture of sophisticated electronic equipment, such testing can be a complex process, involving several different stages. The testing process will vary from manufacturer to manufacturer, but there are certain techniques which are used by most.

2.1 A Typical Manufacturing Test Process

The following basic test steps used at most sites; sometimes they are augmented by additional test steps (such as stress testing).

- Visual Inspection
The components on the circuit board are scanned by operators for obvious defects - poor soldering, or cracked casing etc.
- In-Circuit test
An in-circuit tester is able to make contact with most of the individual components on the board, by laying the board on a 'bed of nails'. It is then able to stimulate each component individually, and ensure that it is performing its correct function.
- Functional test
During functional test, different aspects of the functionality of the entire board are checked. Sometimes, functional test consists simply of sticking the board into a 'known good' system, and turning it on. More often, a series of tests are run on the board, from a specialist functional test system.

More than one test step may be performed on the same test station; combinational testers are able to perform both in-circuit and functional test, for example.

When a board fails visual inspection or in-circuit test, diagnosis is pretty straightforward; the component which is faulty is immediately known as a consequence of the test results. However, when a board fails functional test, there is very little straightforward diagnostic information available. As a result of this, diagnostic technicians are necessary to interpret the results of functional test, perform additional tests and probes as appropriate, and finally to recommend a repair.

Hence a typical process is as follows;

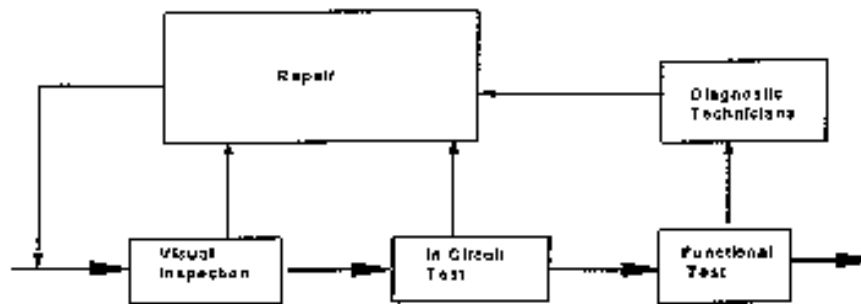

2.2 Pressures on the Manufacturing Test Process

Sometimes, a product will be manufactured for years without any alterations being made to it, so a stable and optimized process can be put in place. However, it is more common nowadays for a manufacturing line to be constantly changing, as new innovations are incorporated into a product.

Typically, a major change will take place every 3-6 months. This means that the manufacturing line must be re-optimized, and experience of a product that the technicians have gained may become redundant, and must be relearned. Hence, for a period of time following the change, the line is sub-optimal, meaning more manufacturing failures, and technicians are less able to diagnose them. Furthermore, in the case of a new product, it is exactly at the initial manufacturing ramp-up that speed is of an essence: the new product must get to market as soon as possible. Support of diagnostic technicians at this time can have great benefits.

3. An Automated Diagnostic Assistant

A tool to aid diagnostic technicians must have the following capabilities;

- It must be able to operate effectively as soon as manufacturing commences, so as to provide assistance to the technicians when they most need it. As a result of this, it must rely only on information available during the design of the product and the tests. Furthermore, it must be able to accept this information quickly and

easily, without a large knowledge acquisition overhead, as the amount of time between test development and manufacturing is small.

- It must be able to work without a knowledge of all types of fault available. Because the way in which a system will fail cannot be 100% predicted from design information, the system must be flexible in its ability to handle 'unknown' faults.
- It must be easy to maintain and upgrade. As the device being tested is likely to be altered regularly, it is important that the system can handle these modifications, and still give effective results. A modification should require a minimal change to the system, and should be handled by a diagnostic technician or test developer.
- The system need not be 100% accurate. It is more important that it provides useful information to the diagnostic technician increasing their efficiency. It should certainly cover the most common cases.
- The system should be such that it is psychologically acceptable to the user. The user should remain in control of the process, and not be told what to do.

In addition to these requirements, it is desirable that the system is fast; if it can process all the functional test results in less than a second, then it can run as part of the manufacturing test line, and be used by operators (see later). When this takes place, manufacturing diagnosis can become significantly more efficient.

4. The JADE System

The JADE system combines a simple model-based approach to diagnosis with probabilistic reasoning. It receives the functional test results direct from the tester, and analyses these to determine which faults are most likely to have caused them. The traditional expert system approach to diagnosis, such as [Allred et. al. 91], has suffered from the fact that expertise is only developed after manufacturing has begun, and that new expertise needs to be gathered for each new product. The model-based approach [Davis 84],[de Kleer and Williams 87], [Reiter 87], advocates reasoning with models of the system to be diagnosed. These models can be obtained at design time. This can be combined with probabilistic information [de Kleer 91], to propose the most likely causes of a given failure. This approach has the disadvantage that the models required are often complex, and so can require a lot of effort to develop.

It uses models of all the tests applied - both good behavior models and, if available, models of how failures can cause specific bad results. The models are specified in terms of how the test acts on the board under test; whether they access memory, output to a specific port, etc. These actions in turn map down onto specific components and component functions. Unlike the structural models traditional used, such models are simple to develop - it takes a test technician a week or so to produce models for a typical functional test suite.

These models can be used in a consistency-based fashion to determine which diagnoses are logically possible. Additionally, the models of tests and actions contain information as to what degree each exercises individual components. This allows a relative weighting to be assigned to each diagnosis, using a Bayes-like probabilistic formula.

The system is able to handle multiple faults effectively, but is not able to handle extreme failures, such as a short-circuit resulting in a failure in a large part of the board.

The system is designed as an aid to diagnostic technicians, and so provides information which would be of assistance to them, rather than aiming to give a definitive correct answer. Hence it outputs a list of candidate diagnoses, in order of relative likelihood, to the technicians. It is up to the technicians to use their discretion in what to do next; if there is one candidate diagnosis far more likely than all the others, they may simply transfer the board straight to repair, or make a visual inspection to confirm the diagnosis. If there are several equally plausible diagnoses, they may perform further testing and probing to determine the true diagnosis. Control of the situation is left in the technicians hands.

5. Benefits of the JADE System

The prototype system outlined above has been deployed at GPCD since October 1992, giving significant benefits in productivity.

Initially, the system was deployed as an assistant to the diagnostic technicians, resulting in a doubling of their productivity. However, it was observed that many of the cases were simple to handle with the JADE system in place, as a detailed visual inspection of the component proposed as the most likely diagnosis would confirm the hypothesis. Hence the system was used instead by a less skilled operator, to weed out the obvious failures as they left the line. The difficult cases were then handed to the technicians, together with the JADE results, for further exploration. Hence, the process described in the earlier section becomes as follows;

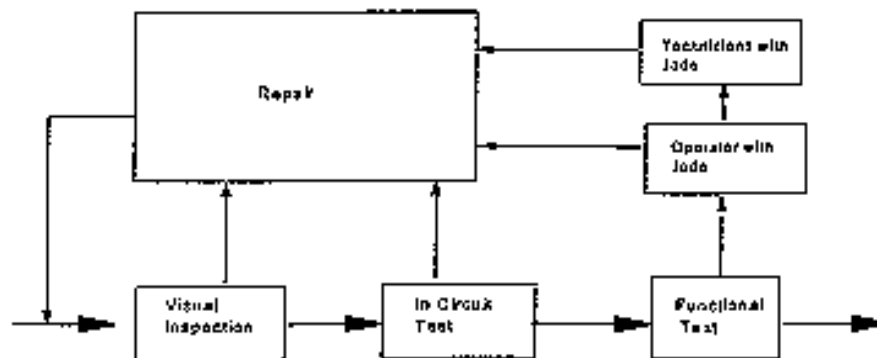

Such a process change resulted in dramatic performance improvements. The operator was three times as productive as a technician without JADE. She was quickly able to filter out the easy cases, so allowing the technicians to concentrate on the harder, and more interesting, cases. Both operator and technicians were happier with their new roles.

This, of course, gave large cost savings in manufacturing. The direct savings resulting from the improved productivity enabled by JADE was 4.5 million francs over the first year. In total, the savings resulting from the new process enabled by JADE was 7 million francs in the first year.

The system also has a very low cost of ownership compared with other approaches. If a new product is to be manufactured, a test technician is able to generate new models as appropriate. Typically, this has taken 2-3 days at GPCD. The system has been used on four different products over the first year of its deployment. Maintenance of the models is simple, requires little effort, and can be performed by test technicians familiar with the system.

6. Conclusions

An automated diagnosis system can result in significant productivity gains in manufacturing test. However, to do this, it must require a relatively small effort to enter product-specific knowledge, and it must be fast. To meet these requirements the JADE prototype (and the subsequent HP fault detective product) has adopted a model-based approach which uses simple models of tests, and combines these with a variant of Bayesian probabilistic reasoning. The resulting system is easy to use and effective, and has resulted in significant cost savings within Hewlett-Packard.

7. References

[Allred et al. 91]

Allred, Lichtenstein, Preist, Bennett and Gupta . AGATHA: An integrated Expert System to Test and Diagnose Complex PC Boards.. *Proc. IJAI 1991*, p87-105

[Davis,1984]

R. Davis. Diagnostic reasoning based on structure and behaviour. *Artificial Intelligence*, 24(1):347-410,1984.

[de Kleer, 1991]

J. de Kleer. Focusing on Probable Diagnoses. In *Proc. 9th National Conf. on Artificial Intelligence*, pages 842-848, Anaheim, CA, July 1991.

[de Kleer and Williams, 1987]

J. de Kleer and B.C. Williams. - Diagnosing multiple faults. *Artificial Intelligence*, 32(1):97-130, April 1987.

[Reiter,1987]

R. Reiter. A theory of diagnosis from first principles. *Artificial Intelligence*, 32(1):57-96, 1987.